

A survey of antenna's miniaturization techniques developed at the University of Nice

C. Luxey, P. Le Thuc, R. Staraj

Abstract – Numerous small antennas have been designed at the Electronics, Antennas and Telecommunication Laboratory (LEAT) of the University of Nice Sophia-Antipolis. In this paper, we perform a detailed analysis of the most interesting concepts. We especially focus on the different miniaturization techniques employed to reduce the size of the antennas.

Index Terms – Small antennas, Planar Inverted-F Antenna (PIFA), patch antennas, mobile phones

1. Introduction

Numerous small antennas have been designed at the Electronics, Antennas and Telecommunication Laboratory (LEAT) of the University of Nice Sophia-Antipolis.

In this paper, we perform a detailed analysis of the best concepts. We especially focus on the different miniaturization techniques employed to reduce the size of the antennas.

2. Meandering the radiator

The most common printed antenna used in the microwave frequency range is the well-known rectangular patch usually positioned a large ground plane. This antenna is generally used in its first resonant mode. At this operating frequency, the currents are approximately covering a half guided wavelength distance along the length of the resonator. One solution to miniaturize such an element consists to modify its geometry while keeping the currents still covering the same distance. For example, etching a slot in the patch force the currents traveling around this slot and thus naturally increase the average path length regarding the initial structure. In this way, if one wants to work at the initial frequency, the surface occupied by the resonator is decreased.

The C-patch is the first miniature antenna designed at the LEAT. This structure is shown in Fig. 1. This antenna is positioned on the corner of a large ground plane.

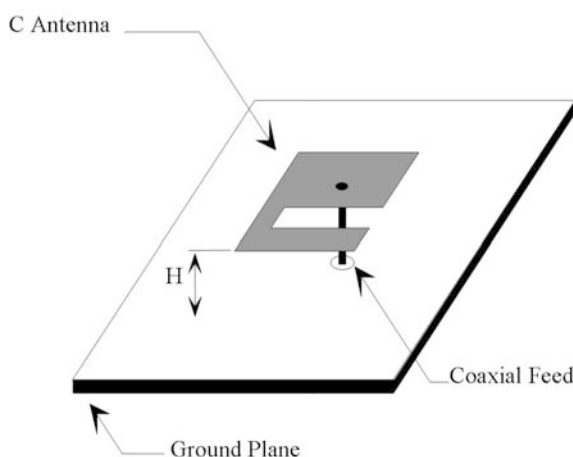

Fig. 1: The C-Patch on a large ground plane [1].

In 1988, two different elements were designed and fabricated to respectively operate in the UHF and the L bands [1]. The miniaturization trick was the one explained above: etch a slot in a square patch antenna to force the currents traveling along this slot. The area reduction gain was about 3 to 4 at the expense of a reduction of the available bandwidth. This is often the case when

miniaturizing radiating elements. It was also observed a degradation of the polarization purity. Depending on the application, this fact may be an advantage in a communication link.

The same concept was extensively used and enhanced by some researchers from Nokia to optimize the occupied space when changing the shape of the slots [2] but also to increase the available bandwidth by adding coplanar [3] and/or stacked C-patch resonators [4].

3. Stacking another radiator

The next miniaturization technique achieved at the LEAT was to vertically stack another C-patch antenna to the previous one while linking them via a small vertical strip [5]. The structure is using air substrate (Fig. 2).

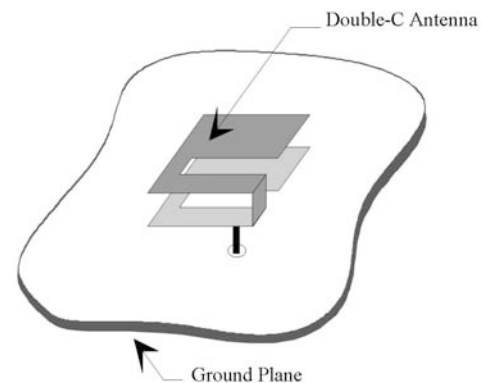

Fig. 2: Stacked C-Patches on a square ground plane.

It can also be described as a folded slot-dipole antenna (Fig.3). The reduction of the dimensions was about 5 at the expense of a small -10 dB bandwidth (3%).

This antenna was further miniaturized using a Duroid substrate with a 2.2 permittivity value [6]: dimension reduction was about 7.5 at the expense of an even more reduced -10 dB bandwidth (0.3%).



Fig. 3: C-Patches as a slot-dipole [5] (before folding).

4. Adding a short circuit

A well-known miniature radiating element is the Planar Inverted F-Antenna (PIFA). The miniaturization technique consists to add a vertical shorting wall in the middle of the resonant length of a patch and remove the other part to get a quarter-wavelength resonator. An additional trick consists to use a partial short circuit instead of an entire shorting wall to further lengthen the current lines flowing in the element to decrease its resonant frequency.

This last technique was applied in 1996 to the previous stacked C-patches ; especially adding a partial short circuit to the lower C-patch (Fig. 4), the structure being still positioned on a large ground plane and using air substrate. It was patented with the help of France Telecom R&D La Turbie (formerly France Telecom Le CNET) [7]. The dimension reductions were about 6 at the expense of a -10 dB bandwidth: 2.5%.

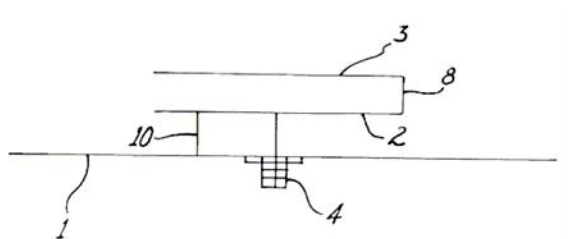

Fig. 4: Short-circuited Stacked C-Patches [6].

5. Combining all the previous techniques

Quarter wavelength resonators for broad-band and dual-band purposes were then designed in 1999 [8]; respectively the S and the E antennas (Fig. 5a and b).

The S antenna is a quarter-wavelength patch with a vertical shorting wall. The main plate is folded in a stacked manner and the element is positioned on a large ground plane (100x100mm²). The antenna was optimized for a dual-band behavior: the achievable ratio between the two operating frequencies was found to be controlled within a range varying from 1.3 to 2.

The E antenna is a structure composed of two superposed quarter-wavelength patches. It was optimized for a broadband operation. A bandwidth of 30% for a VSWR<2 was demonstrated.

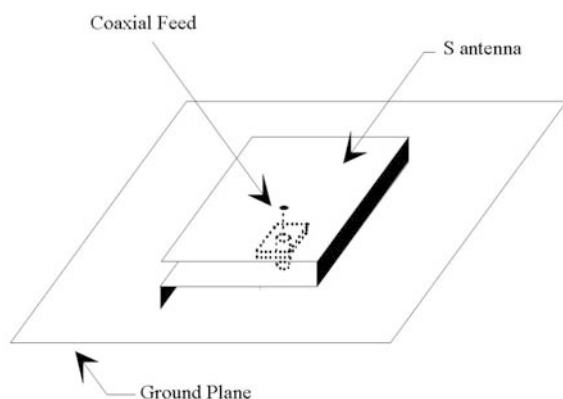

Fig. 5a: S antenna from [8].

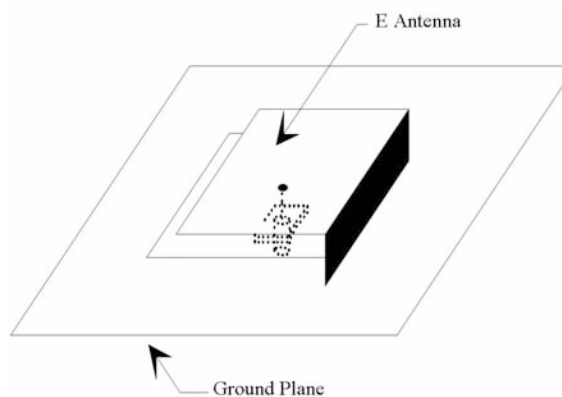

Fig. 5b: E antenna from [8].

Several investigations were conducted to enhance the feeding mechanism of these antennas. Particularly, it was especially found interesting to feed these elements by a coplanar waveguide ended by an open slot. This kind of feeding way has the following advantages: no soldering point, possibility to enhance the bandwidth, easier integration of passive or active components [9].

Equivalent structures having quite the same shapes were also published at the same time [10] and patented [11] by J. Ollikainen and P. Vainikainen from Helsinki University and Technology and Nokia.

6. Using a small ground plane

Two additional techniques were pointed out in the last aforementioned work. Surprisingly, the obtained bandwidths were not as low as the one obtained on a large ground plane. This fact was further explained by other groups [13] like Dirk Manteuffel from IMST [14]. It was found that the PCB size in wavelength could strongly enhance the available bandwidth if chosen to be nearly $\lambda/2$ or $\lambda/4$ and if correctly coupled to the small antenna element. It was also found that a capacitive effect carefully introduced in the resonator was helpful to decrease the high-order resonant modes of the structure without affecting too much the fundamental resonance: this was a real breakthrough to understand how to control the higher resonant frequencies of a PIFA.

In the following years, the LEAT concentrates at 2G mobile communications, especially the intensive use of internal antennas in handsets. The challenge was to design miniature multi-band PIFAs on small ground plane with large bandwidths (>8%).

The first designed concept was a dual-band PIFA positioned at the top of a 100x50mm² ground plane [12]. This antenna consisted in a quarter-wavelength resonator, connected to the Printed Circuit Board (PCB) via a vertical metallic strip as a partial short-circuit and fed by a thin metallic strip connected to a SMA connector (Fig. 6). The end of the antenna was folded under the air space between the main plate and the PCB to create a strong capacitance between these facing metallic parts. This technique was used to keep the same current path length in a reduced area size.

A GSM (880-960 MHz) / UMTS (1920-2170 MHz) antenna was patented with the help of Alcatel Mobile Phone Division and Alcatel Space [15]. The following miniaturization techniques were simultaneously used: slotted-stacked resonators, several shorting posts on the lower and the upper plates (Fig. 7).

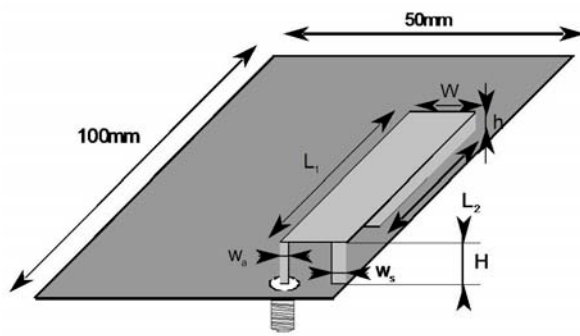

Fig. 6: Dual-band PIFA on a small PCB [12].

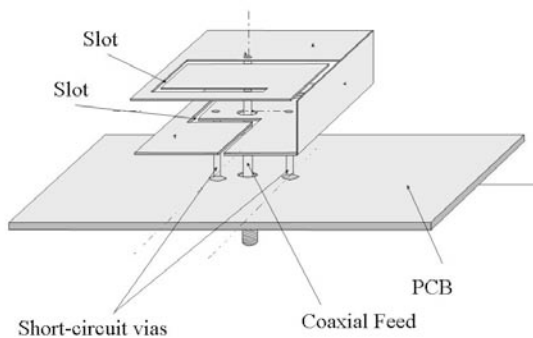

Fig. 7: Patented GSM/UMTS antenna (Alcatel [15]).

The same concept was further optimized to additionally cover the DCS (1710-1880 MHz) and the PCS (1850-1990 MHz) standards (Fig. 8, [16]).

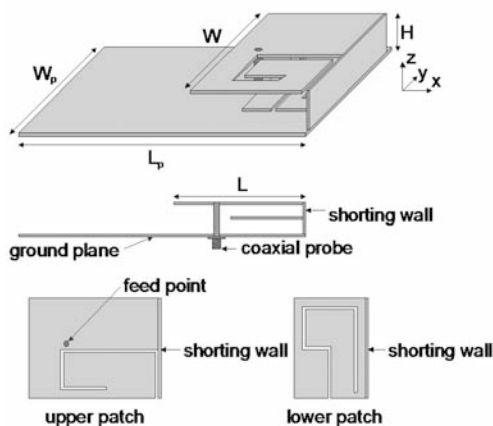

Fig. 8: GSM/DCS/PCS/UMTS antenna

It is also interesting to emphasize that these concepts can be equally analyzed as monopolar wire-patch antennas instead of slotted PIFAs with partial shorting vias [17-18]. Taking into account this kind of approach, a miniature stacked wire-patch antennas on small ground planes was also developed at the LEAT. The challenge was to design a low profile, low cost, large bandwidth and dipolar radiation pattern antenna on a very small ground plane. The antenna had to be suitable for automotive or indoor applications [19]. The optimized ground plane dimensions were only 1.2 times the antenna element (Fig. 9). The small radiator is working like a shorted monopole for GSM frequencies.

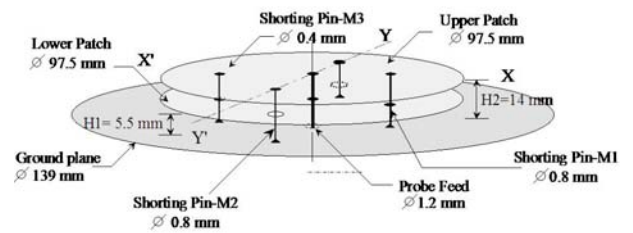

Fig. 9: Miniature GSM wire-patch antenna [19].

The last structures designed at the LEAT are using concurrently all the miniaturization techniques previously described: slotted quarter-wavelength resonators, partial short-circuits, vertical strips as capacitive loads, antenna positioned at the top edge of the PCB and use of coupled to parasitic elements to enhance the available bandwidth.

The first concept was a GSM/DCS/PCS/UMTS PIFA having a 38.5x28.5x8.5 mm³ size on a 100.5x40.5 mm² PCB. All these frequency standards were covered with a VSWR better than 2.5 and high efficiency measured with a home-made Wheeler Cap.

An improvement was the coverage of the HIPERLAN/2 (5150-5350 MHz and 5470-5750 MHz) and the IEEE 802.11a (5150-5350 MHz and 5725-5825 MHz) bands [21]. This was achieved by etching and additional slot in the main resonator to alter the current path length of the fifth resonance of this plate without altering the fundamental and the third modes (Fig. 10).

Finally, some modifications of the previous concept [20] led us to design an antenna also covering the GSM850 US band (824-894 MHz, [22]).

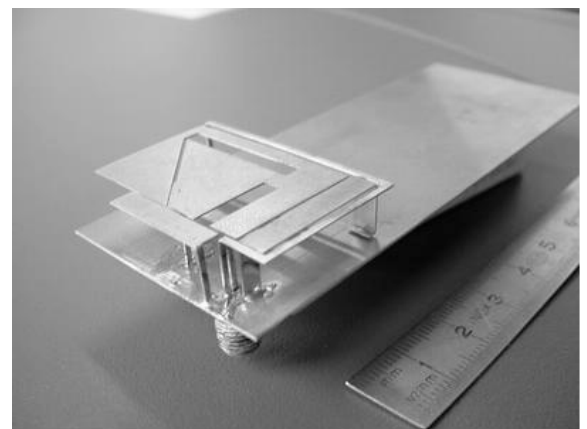

Fig. 10: GSM/DCS/PCS/UMTS/WLAN antenna

7. Conclusion and future issues

Today, with the upcoming implementation of diversity and MIMO techniques in the cellular 3G and 4G communications, the LEAT concentrates on the integration of several antennas on small ground planes while keeping a high isolation between these elements. This has been already done with the introduction of a neutralization effect between two radiators working in very close frequency bands [23]. A prototype with four PIFAs having low mutual coupling and high total efficiencies has been recently presented [24]. Another exciting field of interest of the LEAT, already demonstrated by P. Vainikainen et al. is to use the PCB as the main resonating element, and excited by a non-resonant structure [25].

References

- [1] Kossiavas G., Papiernik A., Boisset J.P., Sauvan M., "The C-Patch - a small microstrip element", Electronics Letters, Vol. 25, N° 4, pp. 253-254, 1989.
- [2] Sanad M., "Double C-Patch Antennas having different aperture shapes", IEEE Antennas and Propagation Society International Symposium, Vol. 4, pp. 2116-2119, Newport Beach, June 1995.
- [3] Sanad M. and Hassan N. "Compact Wide-Band Microstrip Antennas for PCS and Cellular Phones", IEEE Antennas and Propagation Society International Symposium, pp. 152-155, 1998.
- [4] Sanad M. and Hassan N. "Mobile Cellular/GPS/Satellite Antennas with both Single-Band and Dual-Band Feed Points", IEEE Antennas and Propagation Society International Symposium, 2000.
- [5] Zaïd L., Kossiavas G., Dauvignac J.Y. and Papiernik A., "Very compact double C-patch antenna", Electronics Letters, Vol. 34, N° 10, pp. 933-934, May 1998.
- [6] Zaïd L., Kossiavas G., Dauvignac J.Y. and Papiernik A., "Antennes Double C: un élément de très petites dimensions - Double-C patch antenna : a very compact radiating element", Annales des Télécommunications, Tome 54, N° 1-2, pp. 76-84, Janvier-Février 1999.
- [7] Kossiavas G., Papiernik A., Brachat P., Cazajous J., Ratajczak P., "Planar printed-circuit antenna with short-circuited superimposed elements", US Patent N° 5986606, November 1999.
- [8] Zaïd L., Kossiavas G., Dauvignac J.Y. and Papiernik A., "Dual-frequency and broadband antennas with stacked quarter wavelength elements", IEEE Transaction on Antennas and Propagation, Vol. 47, N°4, pp.654-660, April 1999.
- [9] Papiernik A., Carrere J-M., Kossiavas G., Staraj R., "Small stacked antennas fed by coaxial probe or by coplanar waveguide" in Proceedings Millenium Conference on Antennas and Propagation (AP2000), Davos, Switzerland, April 9-14, 2000, Vol. 1, p. 137-140, paper N°172.
- [10] Ollikainen J., Fischer M. and Vainikainen P., "Thin dual-resonant stacked shorted patch for mobile communications", Electronics Letters, Vol. 35, N° 6, pp. 437-438, 18th March 1999.
- [11] Ollikainen J. and Vainikainen P., "Planar Broadband antenna realized with shorted microstrips", US Patent N° 6008764, Dec. 1999.
- [12] Villeger S., Le Thuc P. Staraj R., Kossiavas G., "Dual-band planar Inverted-F antenna", Microwave and Optical Technology Letters, Vol. 38, N° 4, pp. 40-42, 5th July 2003.
- [13] Vainikainen P., Ollikainen J., Kivekäs O and Kelder I., "Resonator-based analysis of the combination of mobile handset antennas and chasis", IEEE Transaction on Antennas and Propagation, Vol.50, N°10, pp. 1433-1444, October 2002.
- [14] Manteuffel D., Bahr A., Heberling D. and Wolff I. "Design consideration for integrated mobile phone antenna", 11th International Conf. on Antennas Propagation, Boston, April 2001, pp. 252-256.
- [15] J-M. Carrere, G. Kossiavas, H. Legay, R. Staraj, "Compact multiband antenna", WO Patent N° 02101874, Dec. 2002.
- [16] Le Thuc P. Staraj R., Kossiavas G., "Dual wideband radiating element for mobile handsets", Microwave and Optical Technology Letters, Vol. 39, N° 4, pp. 288-290, 4th November 2003.
- [17] Delaveaud C., Leveque P., Jecko B., "New kind of microstrip antenna: the monopolar wire-patch antenna", Electronics Letters, Vol. 30, N° 1, pp. 1-2, January 1994.
- [18] Delaveaud C., Leveque P., Jecko B. "Small-sized low-profile antenna to replace monopole antennas", Electronics Letters, Vol. 34, N° 8, pp. 716-717, 16th April 1998.
- [19] Delaveaud C., Leveque P., Jecko B. "Small-sized low-profile antenna to replace monopole antennas", Electronics Letters, Vol. 34, N° 8, pp. 716-717, 16th April 1998.
- [19] Ciaï P., Staraj R., Kossiavas G. and Luxey C., "Design of an Internal Quad-Band Antenna for Mobile Phones", IEEE Microwave and Wireless Components Letters, Vol. 14, N° 4, pp. 148-150, April 2004.
- [20] Ciaï P., Staraj R., Kossiavas G. and Luxey C., "Compact internal multiband antenna for mobile phone and WLAN standards", Electronics Letters, Vol. 40, N° 15, pp. 920-921, 22nd July 2004.
- [21] Ciaï P., Luxey C., Diallo A., Staraj R., Kossiavas G., "Pentaband Internal Antenna for Handset Communication Devices", Microwave and Optical Technology Letters, Vol. 48, N° 8, pp. 1509-1512, 8th August 2006.
- [22] Diallo A., Luxey C., Le Thuc P., Staraj R., Kossiavas G., "Study and reduction of the mutual coupling between two mobile phone PIFAs operating in the DCS1800 and UMTS bands", accepted for publication in the IEEE Transaction on Antennas and Propagation.
- [23] Diallo A., Luxey C., Le Thuc P., Staraj R., Kossiavas G., "Enhanced Diversity Antenna for UMTS handsets", Proceedings of EuCAP2006.
- [24] Villanen J., Ollikainen J., Kivekäs O. and Vainikainen P., "Coupling element based mobile terminal antenna structures", IEEE Transaction on Antennas and Propagation, Vol. 54, N°7, pp. 2142-2153, July 2006.

The authors are very grateful to all the past and present researchers that already contributed to the small antenna researches of the LEAT, especially J.-Y. Dauvignac, P. Brachat, J. Baro, L. Zaïd, J. Cazajous, J-M. Carrere, S. Villeger, P. Ciaï, A. Diallo, P. Le Thuc.

Cyril LUXEY
LEAT-CNRS
University of Nice Sophia-Antipolis
250 Rue A. Einstein
06560 Valbonne
FRANCE
Fax: +33492942812
Cyril.luxey@unice.fr

Philippe LE THUC

Robert STARAJ

(Received on February 23, 2007)
(Revised on February 22, 2007)